



## **Direct Mounted Grilles Type DMG**

**New Street Skelmanthorpe Huddersfield HD8 9BL Telephone 01484 861233 Fax 01484 864928**

All products are manufactured in the UK at the above address

## DIMENSIONAL DATA

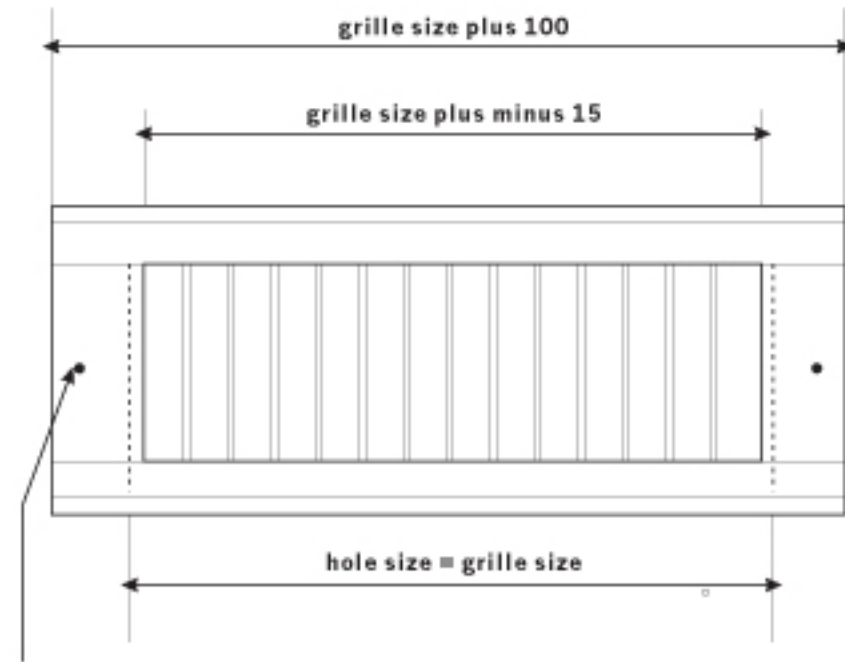

fixing holes to suit no. 8 self tapping screws.  
 screws supplied

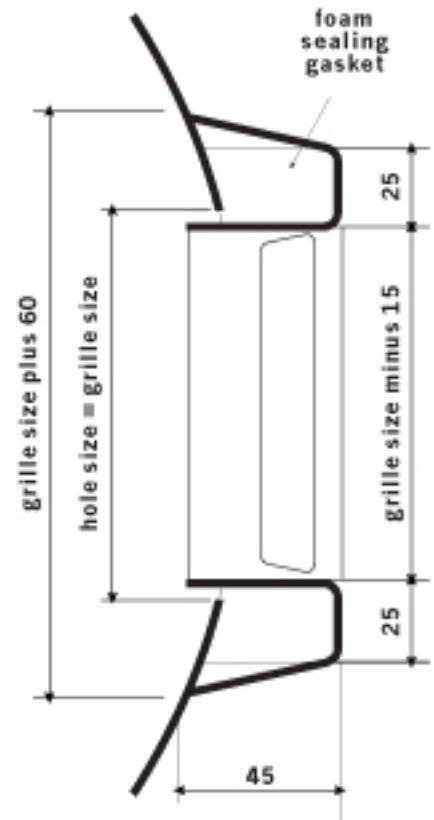

*please specify size of duct when ordering*

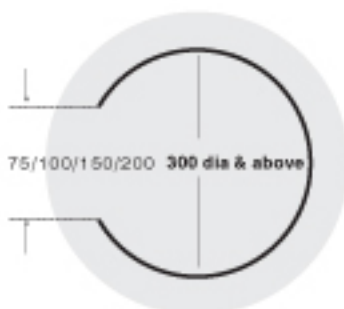
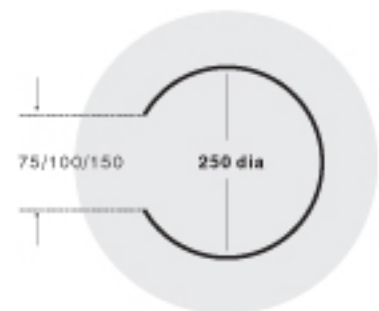
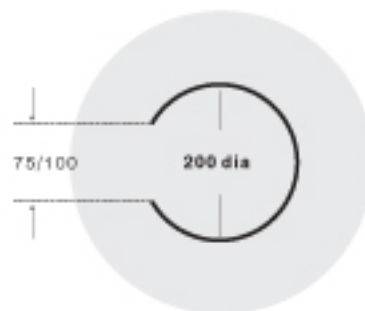
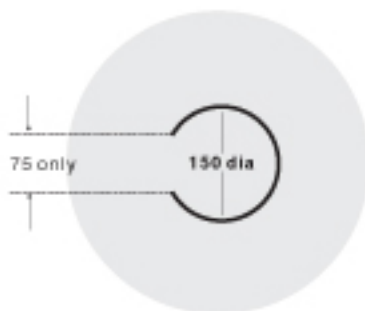

## DIRECT MOUNTED GRILLES

*For use with spiral ducting*

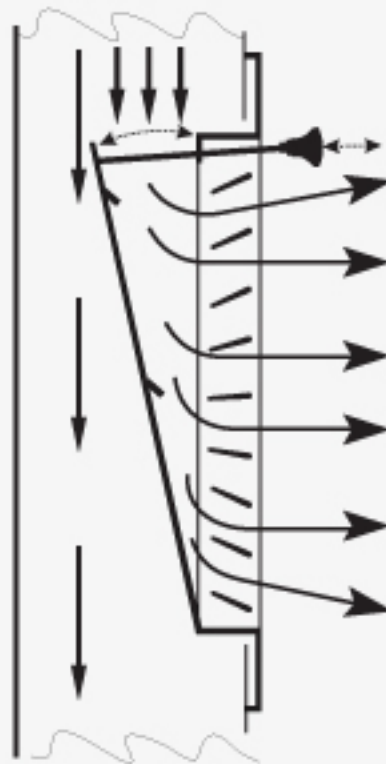

- Fits straight onto circular ductwork including spiral wound - No grille boxes or shoes required.
- Easy to push/pull adjustable damper/deflector - to turn air and balance volume.
- Individually adjustable vertical deflection louvres. - to give sideways spread air diffusion.
- Zinc coated steel construction polyester powder coated in black - for complete corrosion protection.
- Easy two fixing hole attachment - comes complete with foam sealing gasket and fixing screws.
- Sixteen standard sizes to fit all circular ducting down to 150mm diameter.
- Double Deflection Fixed Louvre and Eggcrate variants can be manufactured together with larger sizes both on height and length

## SIZE SELECTION

Grille Type DMG

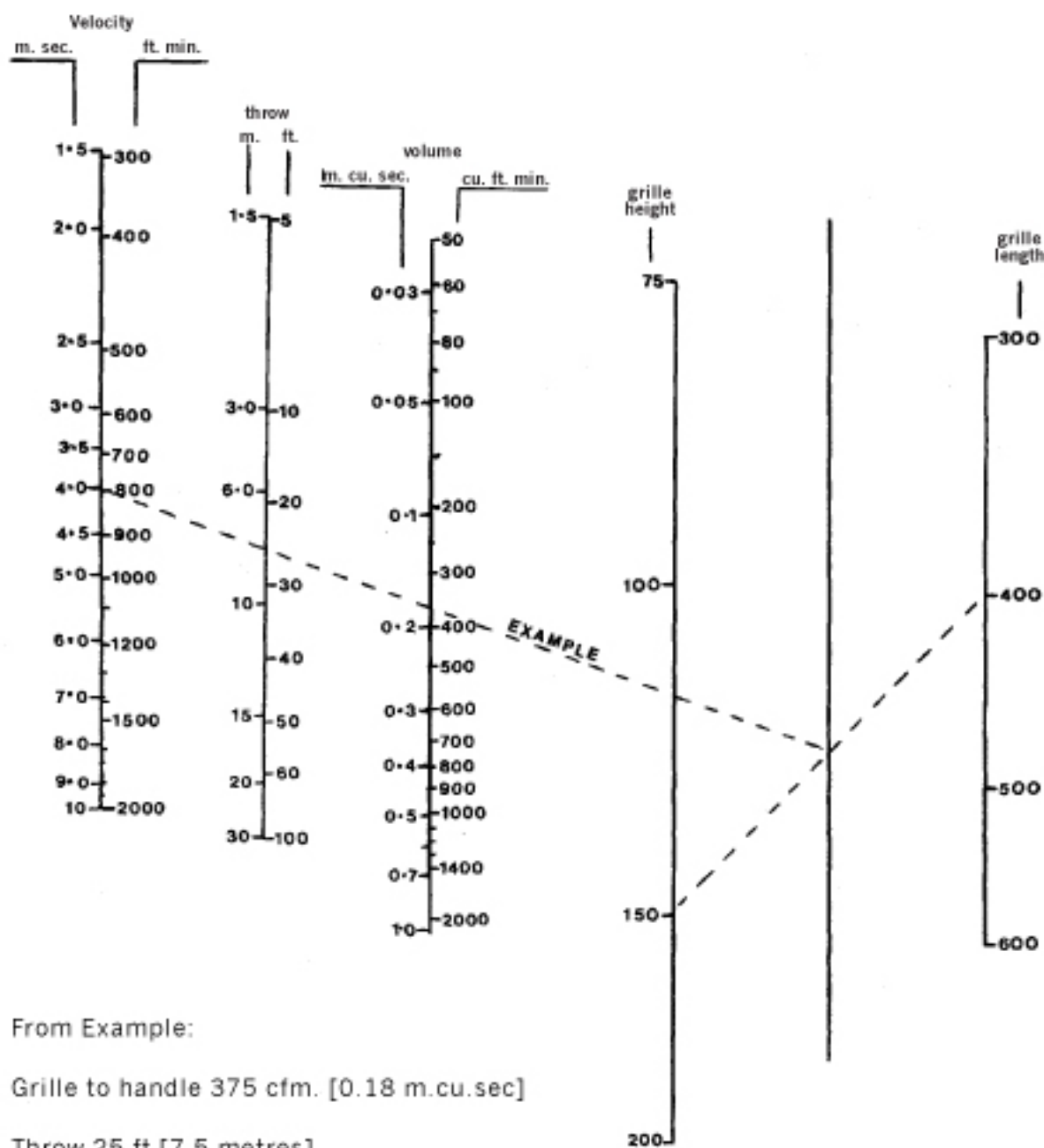

From Example:

Grille to handle 375 cfm. [0.18 m.cu.sec]

Throw 25 ft [7.5 metres]

On the nomogram join 375 cfm air volume to 25 ft throw extending line to velocity and read off 800 ft. min. [4.0 m. sec.]

Extending line back to pivot line and pivoting straight edge about this point, gives a grille size of 400 x 1250mm